

KUZUGAS DN 12 C€ 0051-CPR-0399 EN 14800:2007 GAS MANIFATTURATO-NATURALE-GPL

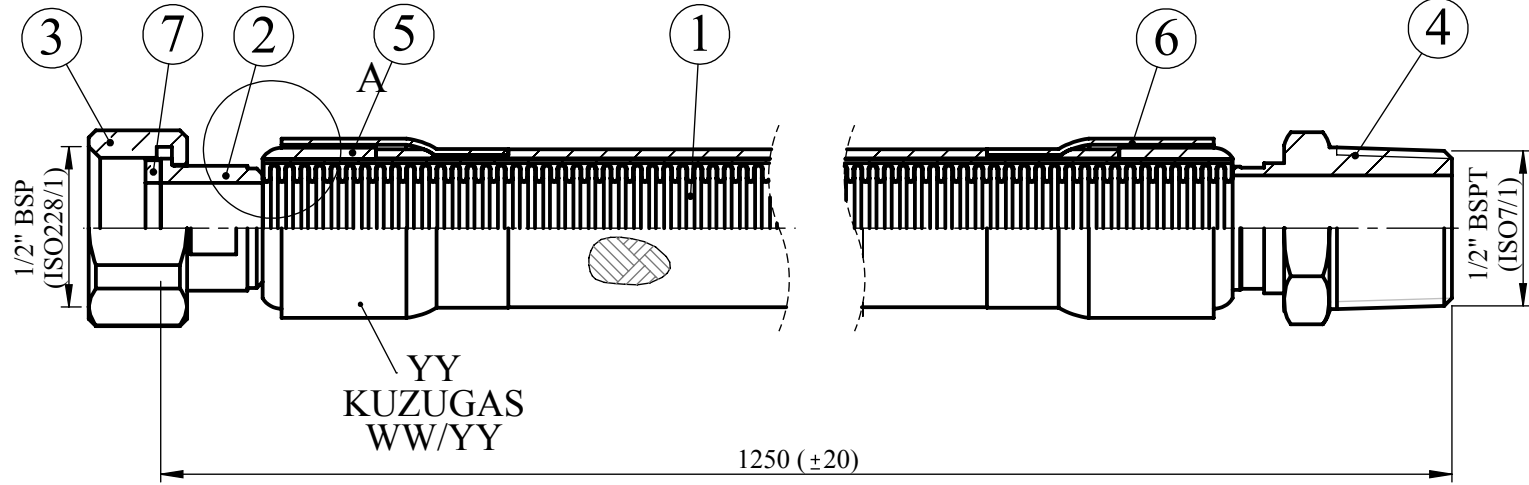

NOT: TRANSPARAN SARI PVC

NOT: ÜRÜN ELDE 2'YE KATLANARAK PAKETLENECEKTİR.

9	LABEL	0000 0611 37	1	
8	TRANSPARENT NYLON	0000 0600 14	1	
7	1/2" GASKET	0000 0004 44	1	NBR
6	RING 2	0000 0005 92	2	AISI304/1.4301
5	DN12 RING	0000 0005 33	2	AISI304/1.4301
4	1/2" BSPT NIPPLE	0000 0004 04	1	AISI303/1.4305
3	1/2" BSP NUT (NICKEL PLATED)	0000 0009 53	1	CW617N/2.0402
2	DN12 LINER	0000 0004 03	1	AISI303/1.4305
1	KZ325 DN12 B + TRANSPARAN YELLOW PVC L=1197mm (It is coated with PVC hose)	0000 0041 89	1	HOSE (AISI316L) PVC
MONTAJ NO PART NR	PARÇA ADI / ITEM NAME	RESIM NO/ DRAWING NO	ADET QTY	MALZEME MATERIAL

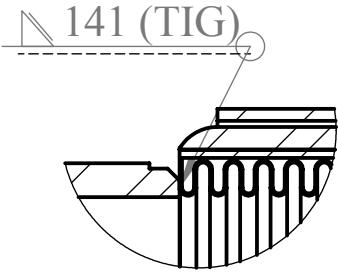

DETAY A
ÖLÇEK 2 : 1

1	Etiket değiştirilmiştir. DBF0259		24.05.2016	SEDA ÇAKIR	BAHRİ BİÇİMSEVEN												
0	İlk yayın		06.08.2015	SEDA ÇAKIR	BAHRİ BİÇİMSEVEN												
Rev.	Description		Date	Drawer	Visa												
General Tolerances EN 22768 f	Angles related to shortest side (mm)					Chamfer & Radius (mm)					Linear Dimensions (mm)					A4	KUZUFLEX® Flexible Metal Hoses
	From To	<10	10 50	50 120	120 400	>400	0,5 3	3 6	>6	<6	6 30	30 120	120 400	400 1000	>1000		
Surface Roughness EN ISO 1302	Tol.	±1°	±30'	±20'	±10'	±5'	±0.2	±0.5	±1	±0.05	±0.1	±0.15	±0.2	±0.3	±0.5	Scale 1/1	Sheet 1/1
ADDITIONAL OPERATION	Heat Treatment	Net Weight	Material	Customer Articiel No	Item Name	Drawing No	Rev.										
		---		---	KZ325 DN12 B ASSEMBLY L=1250mm	0736 0010 00	1										

Certification Level	
Inspection Class	

This drawing and all the information contained can not be used or reproduced, integrity or partially, without written authorization of KUZUFLEX Flexible Metal Hoses