

KUZUGAS DN 12 C€ 0051-CPR-0399 EN 14800:2007 GAS MANIFATTURATO-NATURALE-GPL

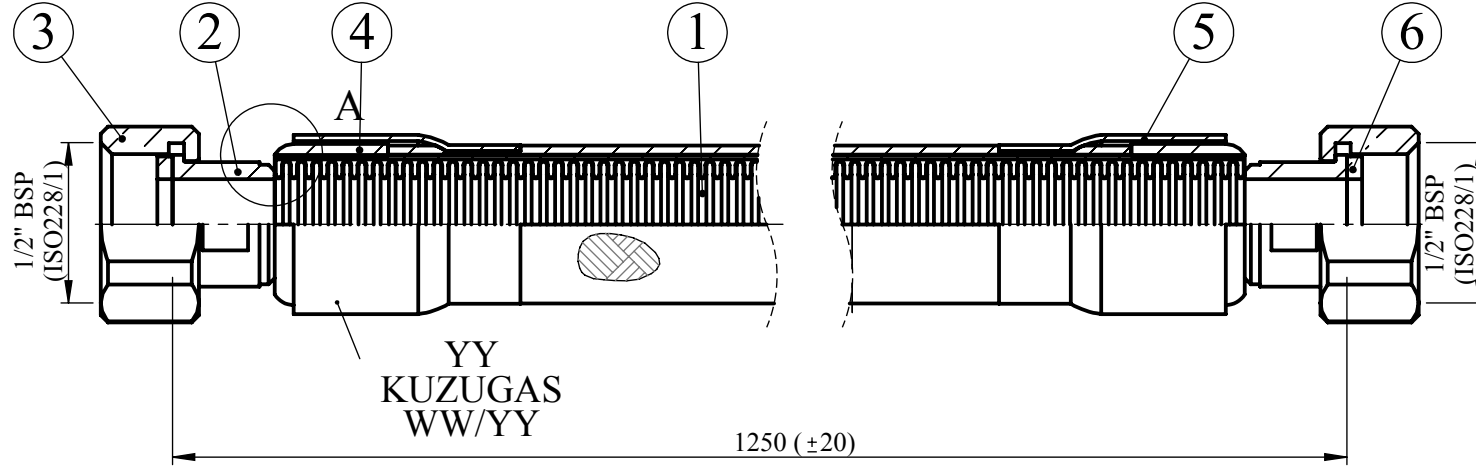

NOT: TRANSPARAN SARI PVC

NOT: ÜRÜN ELDE 2YE KATLANARAK PAKETLENECEKTİR.

MONTAJ NO PART NR	PARÇA ADI / ITEM NAME	RESİM NO/ DRAWING NO	ADET QTY	MALZEME MATERIAL
8	LABEL	0000 0611 36	1	
7	TRANSPARENT NYLON	0000 0600 14	1	
6	1/2" GASKET	0000 0004 44	2	NBR
5	RING 2	0000 0005 92	2	AISI304/1.4301
4	DN12 RING	0000 0005 33	2	AISI304/1.4301
3	1/2" BSP NUT (NICKEL PLATED)	0000 0009 53	2	CW617N/2.0402
2	DN12 LINER	0000 0004 03	2	AISI303/1.4305
1	KZ325 DN12 B + TRANSPARENT YELLOW PVC L=1208mm (It is coated with PVC hose)	0000 0041 89	1	HOSE (AISI316L) PVC

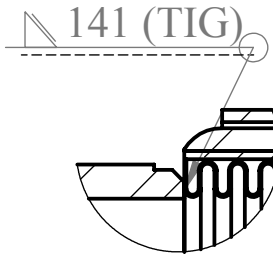

DETAY A
ÖLÇEK 2 : 1

Rev.	Description	Date	Drawer	Visa																																																								
1	Etiket değiştirilmiştir. DBF0259	24.05.2016	SEDA ÇAKIR	BAHRİ BİÇİMSEVEN																																																								
0	İlk yayın	06.08.2015	SEDA ÇAKIR	BAHRİ BİÇİMSEVEN																																																								
<table border="1"> <thead> <tr> <th>General Tolerances EN 22768 f</th> <th colspan="5">Angles related to shortest side (mm)</th> <th colspan="3">Chamfer & Radius (mm)</th> <th colspan="6">Linear Dimensions (mm)</th> <th colspan="2">Scale 1/1</th> <th colspan="2">Sheet 1/1</th> </tr> <tr> <td></td> <td>From</td> <td><10</td> <td>10</td> <td>50</td> <td>120</td> <td>>400</td> <td>0,5</td> <td>3</td> <td>>6</td> <td><6</td> <td>6</td> <td>30</td> <td>120</td> <td>120</td> <td>400</td> <td>>1000</td> <td colspan="2">A4</td> </tr> <tr> <td>Surface Roughness EN ISO 1302</td> <td>Tol.</td> <td>±1°</td> <td>±30'</td> <td>±20'</td> <td>±10'</td> <td>±5'</td> <td>±0.2</td> <td>±0.5</td> <td>±1</td> <td>±0.05</td> <td>±0.1</td> <td>±0.15</td> <td>±0.2</td> <td>±0.3</td> <td>±0.5</td> <td colspan="2">KUZUFLEX® Flexible Metal Hoses</td> </tr> </thead> </table>					General Tolerances EN 22768 f	Angles related to shortest side (mm)					Chamfer & Radius (mm)			Linear Dimensions (mm)						Scale 1/1		Sheet 1/1			From	<10	10	50	120	>400	0,5	3	>6	<6	6	30	120	120	400	>1000	A4		Surface Roughness EN ISO 1302	Tol.	±1°	±30'	±20'	±10'	±5'	±0.2	±0.5	±1	±0.05	±0.1	±0.15	±0.2	±0.3	±0.5	KUZUFLEX® Flexible Metal Hoses	
General Tolerances EN 22768 f	Angles related to shortest side (mm)					Chamfer & Radius (mm)			Linear Dimensions (mm)						Scale 1/1		Sheet 1/1																																											
	From	<10	10	50	120	>400	0,5	3	>6	<6	6	30	120	120	400	>1000	A4																																											
Surface Roughness EN ISO 1302	Tol.	±1°	±30'	±20'	±10'	±5'	±0.2	±0.5	±1	±0.05	±0.1	±0.15	±0.2	±0.3	±0.5	KUZUFLEX® Flexible Metal Hoses																																												
ADDITIONAL OPERATION		Heat Treatment	Net Weight	Material	Customer Article No	Item Name		Drawing No		Rev.																																																		
			---		---	KZ325 DN12 B ASSEMBLY L=1250mm		0736 0004 00		1																																																		

Certification Level	
Inspection Class	

This drawing and all the information contained can not be used or reproduced, integrity or partially, without written authorization of KUZUFLEX Flexible Metal Hoses